



Clark County's Strategic Response to Support Southern Nevada's Plan to End Homelessness

Proposal Overview

Presented to the Southern Nevada Homelessness CoC

May 9, 2019

Mike Pawlak, Social Service Director

Michele Fuller- Hallauer, Social Service Manager

The 2018 Point-in-Time (PIT) Count identified 6,083 homeless persons in Southern Nevada.

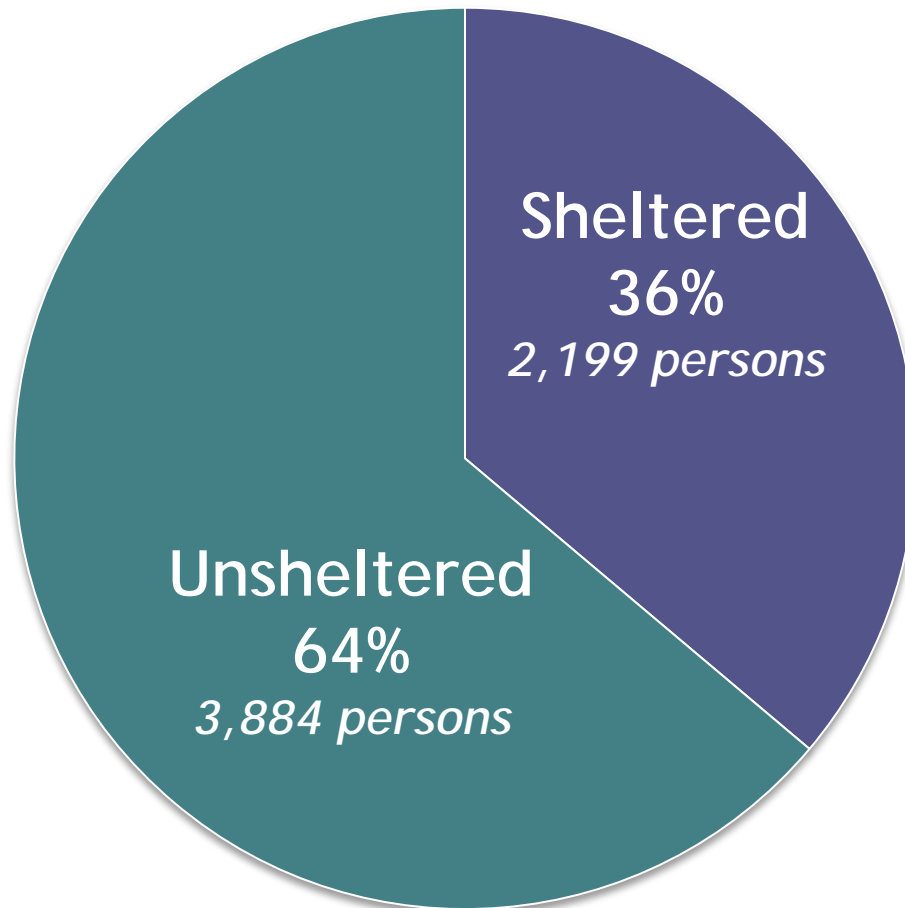

*2019 PIT Count anticipated to be released June 2019.

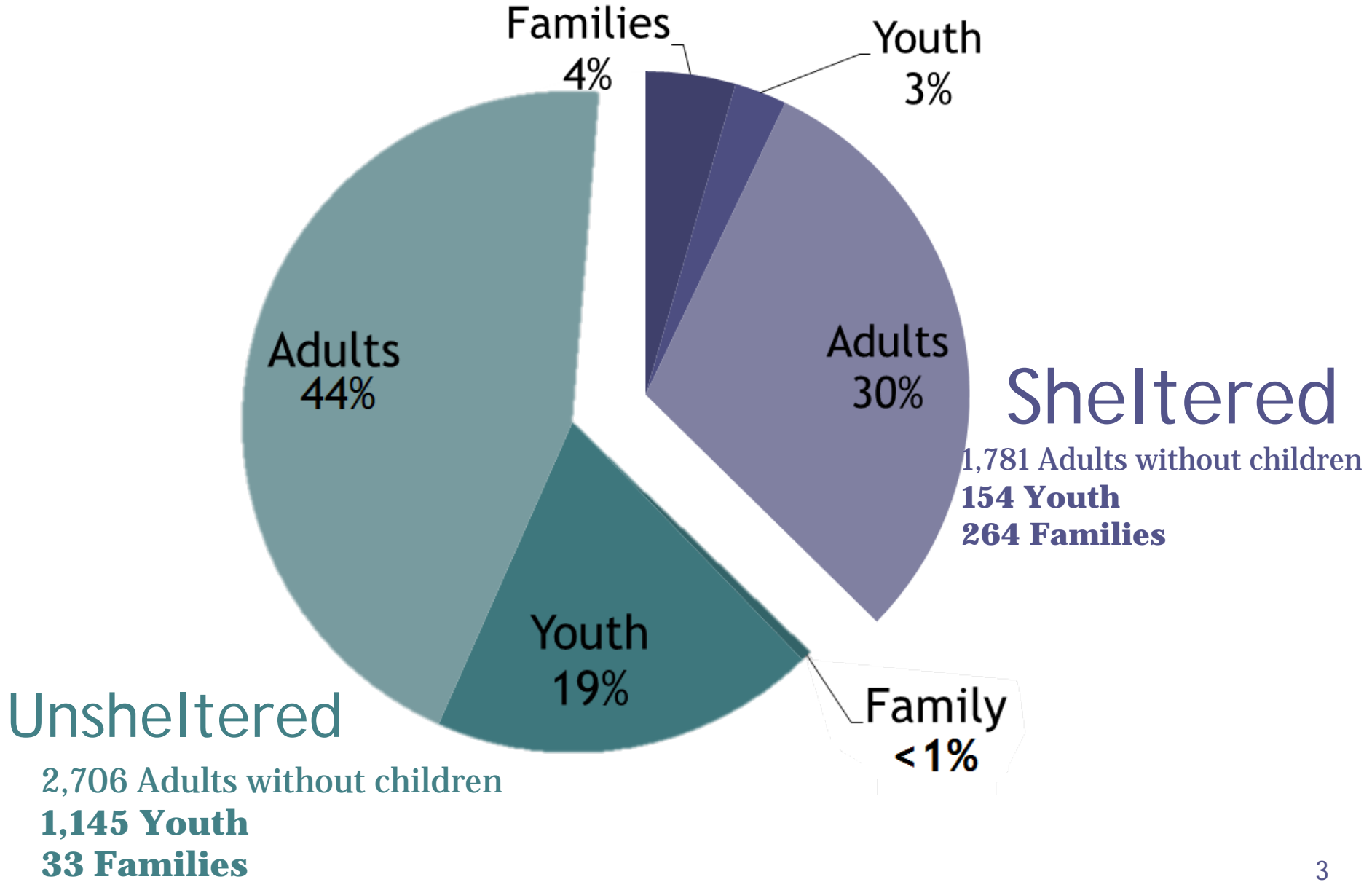

Our Homelessness System of Care

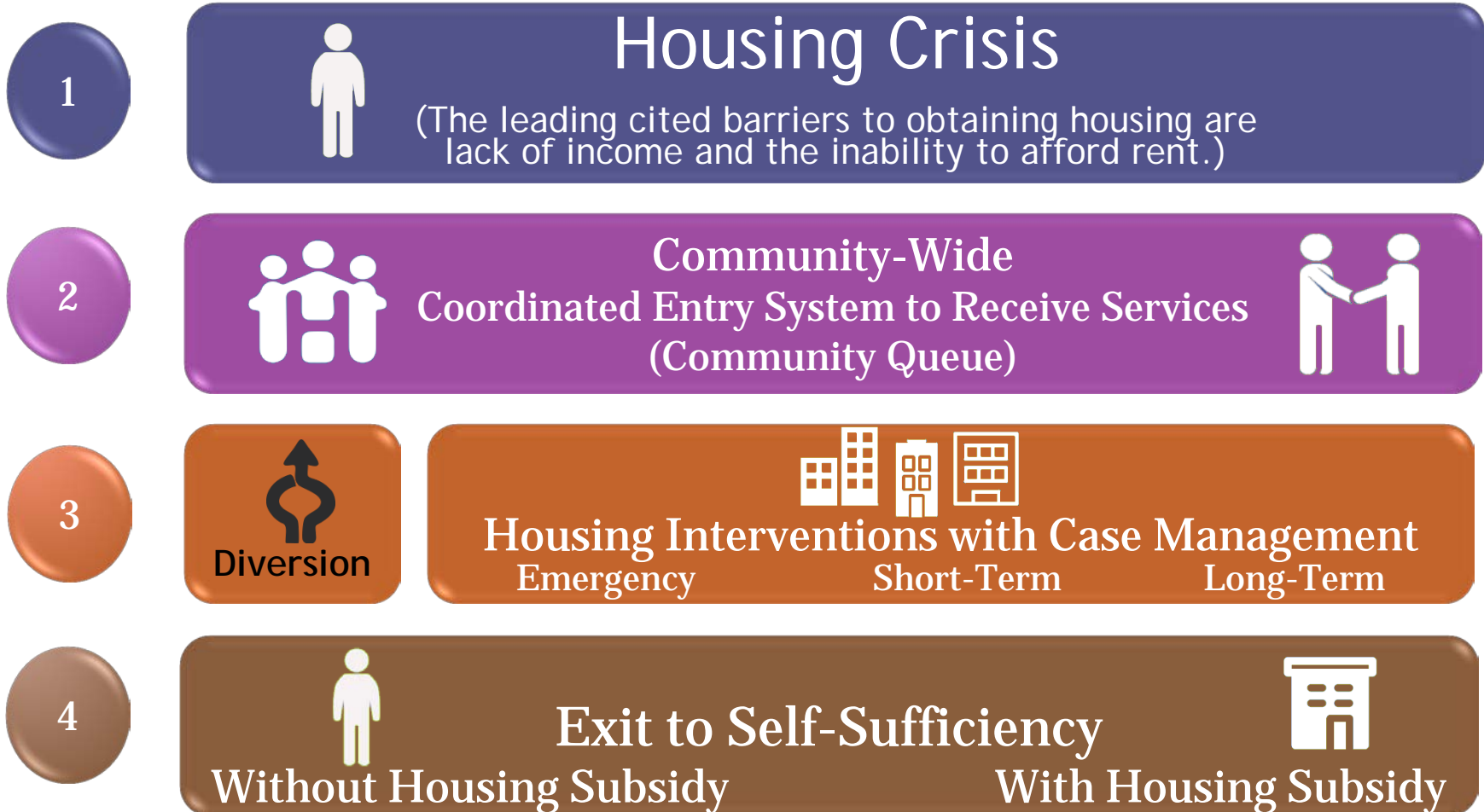

Current Housing Interventions



Diversion



Emergency Shelter/Crisis Stabilization



Bridge Housing

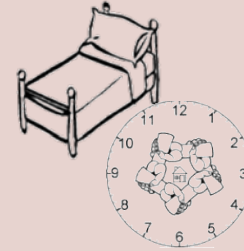

Transitional / Rapid-Rehousing



Permanent Supportive Housing

Divert families from homeless services by providing assistance so they can maintain housing

Improve the capacity of the crisis stabilization and emergency shelter system and connect to supportive housing

Provide immediate housing and services for families eligible for housing programs

Assist families and youth move to self-sufficiency through flexible housing options and limited case management

Offer permanent housing options and intensive case management to families, youth and individuals

Clark County's Contribution: Supporting a Healthy System

Outreach \$1.35 Million

Mobile Crisis Intervention Team MCIT) + LINK Outreach
\$1.2 Million

Street Outreach Program Youth (YO Team)
\$150,000

Bridge Housing \$3.2 Million

Bridge Housing Program
\$2 Million

Bridge (FAS)
\$1,200,000

Community Support/Capacity Building \$1.1 Million

Outside Agency Grant
\$1.1 Million

Prevention/Diversion \$33.1 Million

Financial Assistance (FAS)
\$5.8 Million

Welfare Set-Aside Program (WSAP)
\$658,770

Indigent Nursing Home
\$24 Million

Group Care
\$1.2 Million

Homemaker Services
\$1.2 Million

HPFTAY
\$250,000

Emergency Housing \$2.3 Million

Year Round Shelter
\$1.3 Million

Inclement Weather Shelter
\$673,919

Emergency Shelter Program (ESG)
\$347,973

Transitional/Rapid Rehousing \$3.72 Million

Hospital to Home
\$546,141

ESG-RRH Program (ESG)
\$231,982

CABHI/LIHTF TBRA
\$1,006,526

Keeping Families Together (NCE)
\$164,000

Living Beyond 2
\$194,000

STAR TH-RRH
\$1,580,916

Permanent Supportive Housing \$5 Million

New Beginnings
\$1,385,908

Healthy Living
\$568,648

Built for Zero Public/Private Partnership
\$528,000 (NCE-Vivo)

Next Step (NCE-FUSE)
\$890,000

STAR PSH
\$1,607,673

Bold represents Clark County Funds

What we have...providing housing options to 5,336 persons



Diversion



Emergency Shelter / Crisis Stabilization



Bridge Housing

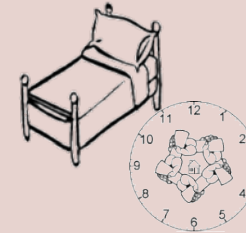

Transitional / Rapid-Rehousing



Permanent Supportive Housing

Limited and not well coordinated

1290 beds (57 are VA Beds)

90 Beds (varies, dependent on caseload size)

568 TH Beds (298 are VA Beds) /
662 RRH Beds (88 are VA Beds)

2,726 Beds (1,546 are VA Beds)

Our mission is to develop and maintain a healthy system of care to address the needs of persons experiencing housing crisis in Southern Nevada.

Vision

- Build upon work done by existing programs of the Southern Nevada Homelessness Continuum of Care (CoC)
- Address gaps in systems of care using non-federal funding
- Utilize flexible funding to drive innovative solutions



Immediate Short Term Goals

Goal 1

- House all families and youth in the queue

Goal 2

- House system-involved families and youth impacting County Departments (Department of Family Services/Juvenile Justice Services)

Goal 3

- Expand shelter options/housing for persons experiencing **unsheltered** homelessness

Goal 4

- Address system gaps using non-federal funding and drive unique and innovative solutions

Goal 1

- House all families and youth in the queue

Average # of Persons in the Community Queue

<i>Families</i>	<i>Youth/Young Adults (0 – 24 years)</i>	Adults without Children
195	91	1,385

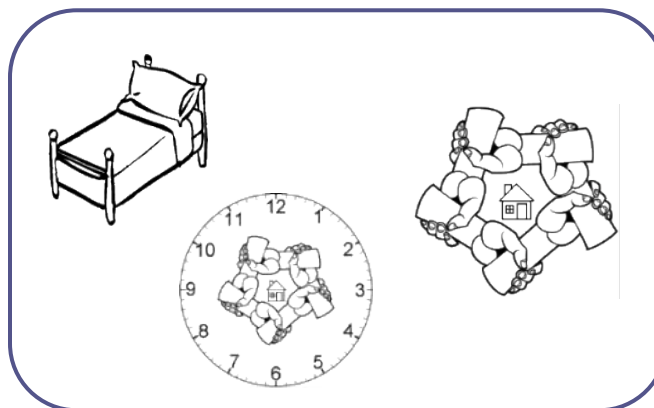
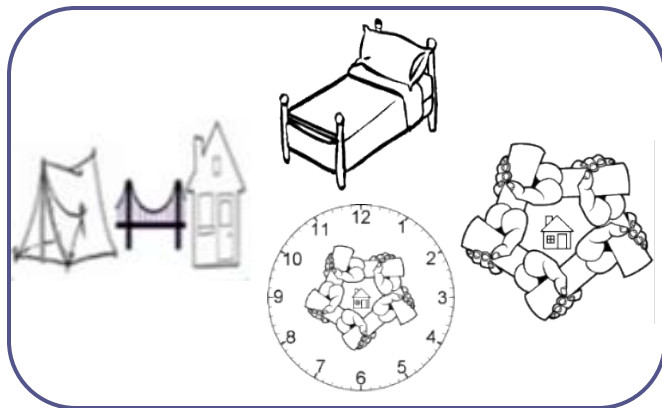
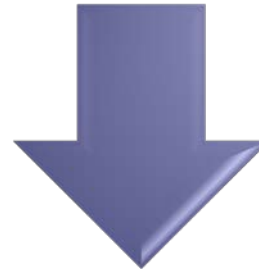
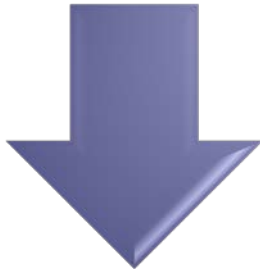

Goal 1

- House all families and youth in the queue

Implementation includes:

- Scale up Bridge Housing Program for families
- Increase the number of Transitional /Rapid Re-Housing and Permanent Supportive Housing units
- Secure master leases to obtain additional housing units

Duration: 12 – 18 months

(Barriers: units, hiring, contracting)

Begin Housing



Provide Rent
and Supportive
Services



Sustainability



Goal 2

- House system-involved families and youth impacting County Departments (Department of Family Services/Juvenile Justice Services)

Average # of Persons needing assistance

<i>Families with Children in Care</i>	<i>Discharged Justice Involved Youth</i>	Adults with Medical Fragility
100*	100*	60

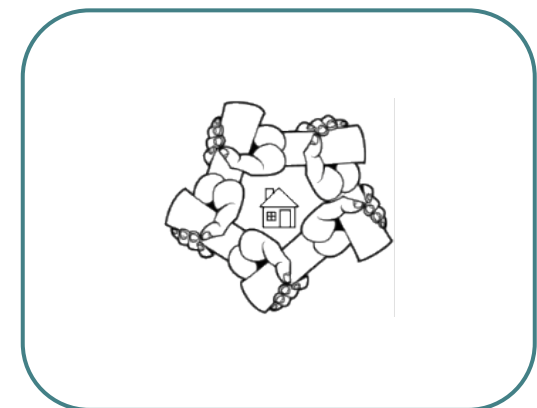
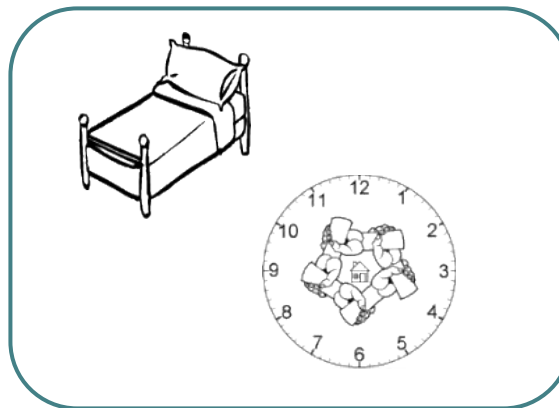
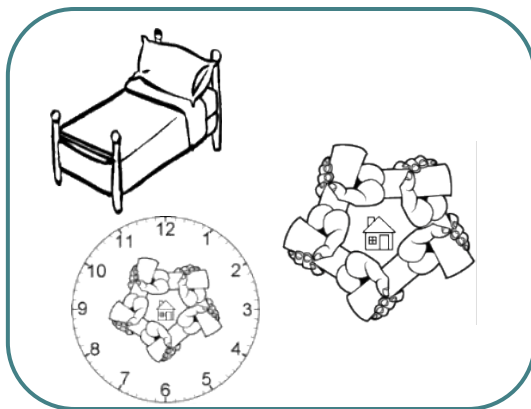

*estimates from DFS and DJJS

Goal 2

- House system-involved families and youth impacting County Departments (Department of Family Services/Juvenile Justice Services)

Implementation includes:

- Establish Step Up (current program housing aging-out foster youth) look-a-like program for juvenile justice involved youth
- Revive/Expand the Keeping Families Together collaborative program between DFS & CCSS
- Expand Hospital to Home public/private partnerships based on best practices maximizing managed care organizations blended funding model

Duration: ongoing

Begin Interventions



Continue Programming



Goal 3

- Expand shelter options/housing for persons experiencing **unsheltered** homelessness

Average # of Persons needing assistance		
<i>Families</i>	<i>Youth</i>	Adults without Children
33	1,145	2,706

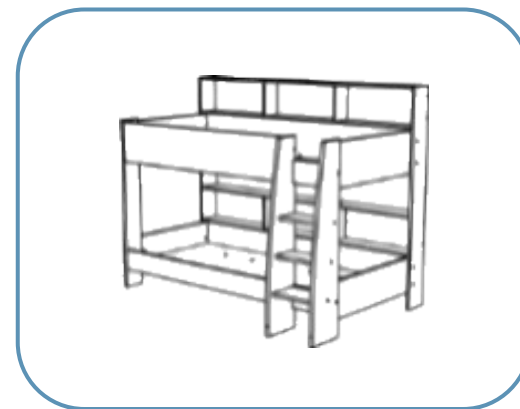

Goal 3

- Expand shelter options/housing for persons experiencing **unsheltered** homelessness

Implementation includes:

- Expand youth shelter beds and housing
- Expand low barrier shelter beds throughout the community

Duration: ongoing

Begin Interventions



Continue Programming



Goal 4

- Address system gaps using non-federal funding and drive unique and innovative solutions

Diversion

- Divert people from entering homelessness
- Coordinated regional tracking of providers and outreach

Landlords

- Increase number of participating landlords and add units, units, units

Moving On With Increased Capacity

- Develop churn in the system by helping clients move on when they are ready

Goal 4

- Address system gaps using non-federal funding and drive unique and innovative solutions

Implementation includes:

- Develop diversion program with flexible combination of short-term services and financial assistance such as:
 - One month rental assistance
 - Car repair
 - Utility deposit or payment of arrears
- Expand initiatives and create pool of flexible funding incentives for housing units and programming
- Develop shallow subsidy program to free up other permanent housing beds



Diversion

+376 beds



Emergency Shelter/Crisis Stabilization

+180 beds



Bridge Housing

+633 beds*

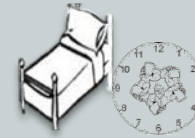

Transitional / Rapid-Rehousing

+60 beds **



Permanent Supportive Housing

Develop pilot program including:

- Train providers
- Create flexible fund
- Establish standards
- Track Outcomes

- Add **76** shelter beds for Youth
- Add **300** community-wide, low barrier housing shelter beds

-Implement at least **180** family bridge housing placements based on best practice

- Keep **100** justice involved youth from cycling into homelessness
- Keep **100** welfare-involved families together through reunification efforts
- Add **200** RRH beds by expanding high performing projects

-Add **60** PSH beds by expanding high performing PSH projects

Establish Aggressive Campaign for Affordable Housing Opportunities

*100 welfare-involved families include approximately 133 adults and 200 children

** 1,249 total beds added to system of care

Acronyms

- HUD: US Department of Housing & Urban Development
- SNH CoC: Southern Nevada Homelessness Continuum of Care
- SN-CHAT: Southern Nevada Community Housing Assessment Tool
- PIT: Point-in-Time Homeless Count
- AWOC: Adults without Children
- Youth: Youth aged up to 24
- BFZ: Built for Zero
- FUSE: Frequent Users of System Engagement
- CABHI: Cooperative Agreement to Benefit Homeless Individuals
- LIHTF: Low-Income Housing Trust Fund

Housing Types

- ES: Emergency Shelter
- TH: Transitional Housing
- RRH: Rapid Rehousing
- PSH: Permanent Supportive Housing
- TBRA: Tenant Based Rental Assistance

County Departments

- CCSS: Clark County Social Service
- DFS: Department of Family Services
- DJJS: Department of Juvenile Justice Services

Questions...